

Mod. CG – PE

Mod. CG - PR

PRESSE PNEUMATICH
PRESS PNEUMATIC
PRESSE PNEUMATIQUE



COCCHI



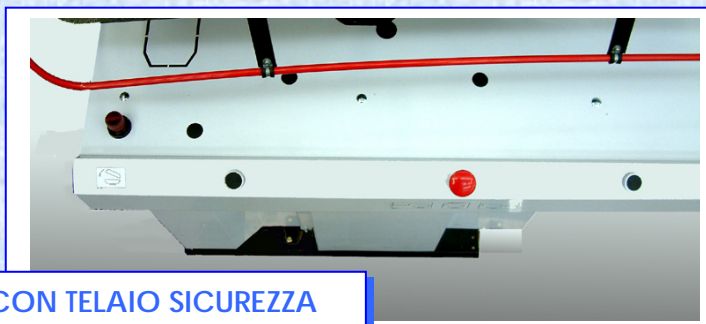

**CHIUSURA A 2 PULSANTI CON TELAIO SICUREZZA
FERMETURE AVEC 2 BOUTONS ET CHASSIS SECURETE
CLOSING BY 2 BUTTONS AND SECURITY-FRAME**

OPTIONALS

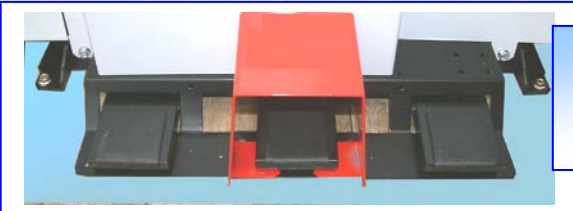

**CHIUSURA A PEDALE
FERMETURE PAR PEDALE
CLOSING BY PEDAL-SWITCH**



Mod.CV-1

INOX

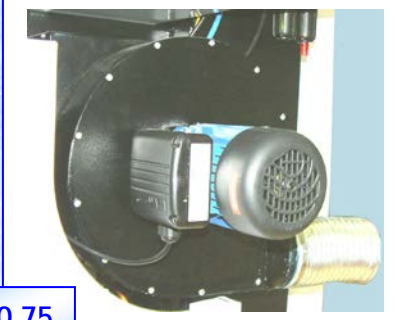

HP 0,75



**CALDAIA
CHAUDIERE
BOILER**

**LT. 16
Inox /
LT. 24**

**Resistenze
Resistances
Elements 12.15.18 Kw**

**CONTROLLO ELETTRONICO A 3 SONDE
CONTROLE ELECTRONIQUE A 3 SONDRES
ELECTRONIC CONTROL AT 3 PROBES**

**GRUPPO DI RESISTENZE
GROUPE DE RESISTANCE
ELEMENTS GROUP**



3/8" in S.S.INOX



Mod. CG-PM

PRESSA MANUALE
MANUAL PRESS
PRESSE MANUELLE

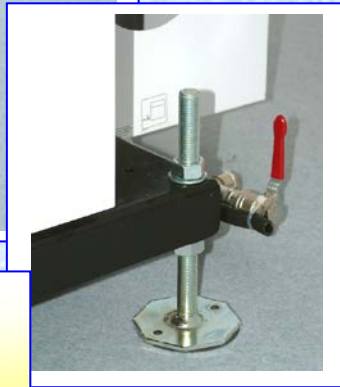

REGOLAZIONE ALTEZZA PRESSA
REGULATION HAUTEUR PRESSE
HEIGH-PRESS ADJUSTEMENT

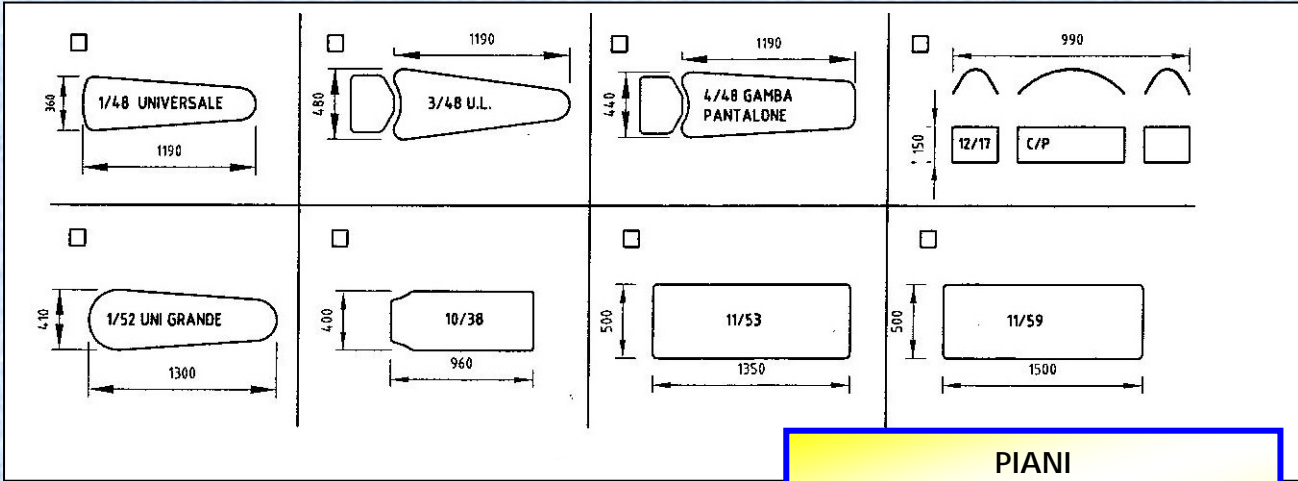

PIANI
BOARDS
PLATEAUX

Mod. CG-PR.R



OPTIONALS CG-PE / CG-PR /CG-PM

CALDAIA AUTOMATICA INCORPORATA 24 LTS – 12.15.18 KW
MOTORE ASPIRAZIONE HP 0,75
MOTORE ASPIRAZIONE -SOFFIATURA HP 0,75
GRUPPO FERRO STIRO + FERRO 1000 W
CHIUSURA A 1 PEDALE
AUTOMAZIONE CON PROGRAMMATORE
PISTOLA VAPORE
PISTOLA ARIA-VAPORE
PLATO' SUPERIORE LUCIDO

CHAUDIERE AUTOMATIQUE INC. 24 LTS - 12.15.18 KW
MOTEUR ASPIRATION HP 0,75
MOTEUR ASPIRATION-SOUFFLERIE HP 1
GROUPE FER A REPASSER + FER 1000 W
FERMETURE AVEC 1 PEDALE
AUTOMATION AVEC PROGRAMMATEUR
PISTOLET VAPEUR - PISTOLET AIRE-VAPEUR
PLATEAU SUPERIEUR POLI

AUTOMATIC BOILER INC. 24 Lts – 12.15.18 KW
VACUUM MOTOR HP 0,75
VACUUM-BLOWING MOTOR HP 1
IRON GROUP + IRON 1000 w
CLOSING UPPER BOARD BY PEDAL
ELECTRONIC PROGRAMMATOR
STEAM GUN - AIR.STEAM GUN
UPPER BOARD POLISHED

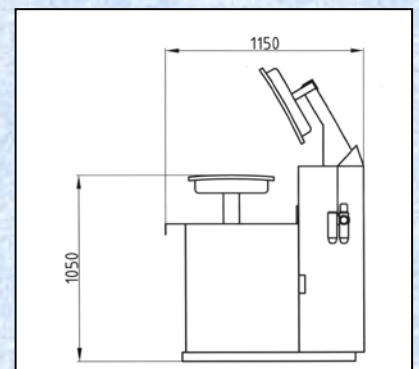
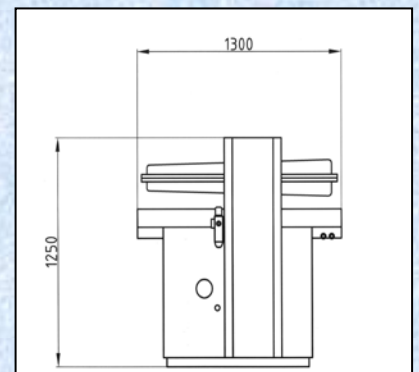

COCCHI srl

via Pacinotti 19/a – 40017 San Giovanni in Persiceto – Bologna – Italy
tel. ++39 051 821787- fax ++39 051 826935
web site : www.cocchi.net email : info@cocchi.net

