

Mod. **CG-BJ**



®

**COCCHI**



## Mod. CG-BJ

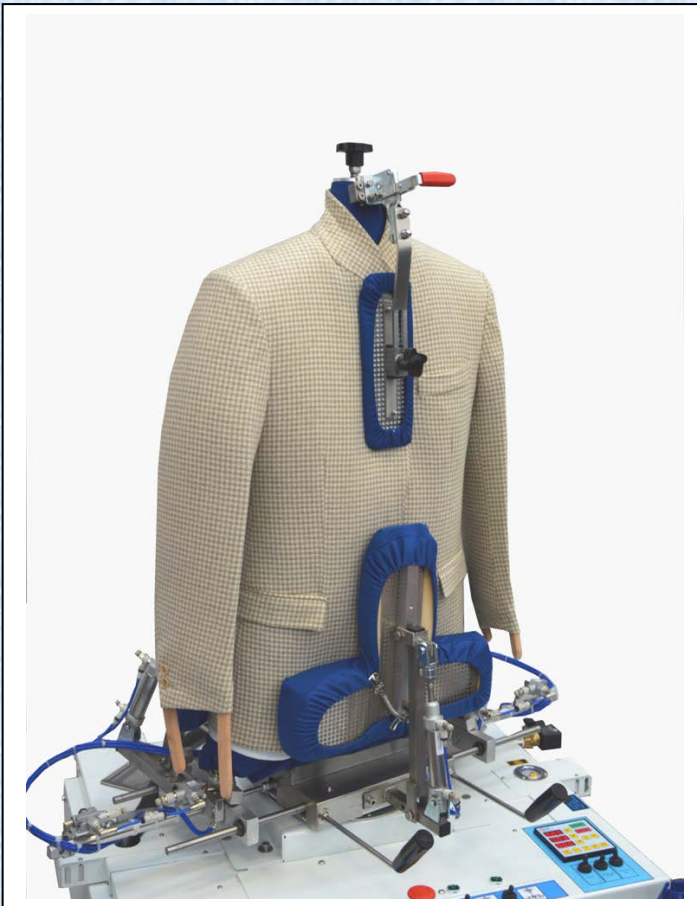

MACCHINA CONCEPITA PER LA STIRATURA DI GIACCHE, CAPPOTTI, CAMICI, GIUBBOTTI in genere a livello industriale.

La REGOLAZIONE pneumatica dell'ALTEZZA permette la Stiratura di molteplici lunghezze, concedendo al tempo stesso un "tiraggio" verticale del tessuto che ne ottimizza il tensionamento durante la potente vaporizzazione e soffiatura.

Dotata di due Estensori pneumatici Lateralì, una pala frontale e tre posteriori, il busto permette un imbragamento del capo estremamente funzionale ed efficace.



MACHINE REALIZED TO IRONING JACKETS, COATS, OVER COATS IN GENERAL AT INDUSTRIAL SCALE with pneumatic Functions. The pneumatic adjustment of the height allows the Ironing of many lengths, and at the same time the cloth is "stretched" vertically, so that, with the powerful blowing and steaming the ironing quality reaches a high level.

Equipped with 2 side stretching devices, a frontal shovel and three posterior ones, the dummy allow an efficient and functional placing of the garment.



MACHINE CONCUE POUR LE REPASSAGE INDUSTRIEL DE VESTES, MANTEAUX, BLOUSONS ET SIMILAIRE.

LE REGLAGE pneumatique DE L' HAUTEUR permet de repasser Plusieurs longueurs, en assurant un « tirage » vertical du tissu permettant une mise en tension optimale pendant la forte vaporisation et soufflerie.

Equipée de deux ecarteurs lateraux, une palette frontale et trois posterieures le buste permet un blocage du vetement particulièrement efficace et fonctionel,



**PALE PNEUMATICHE POSTERIORI PER SPACCHI**

**PALETTES POSTERIEURES PNEUMAT. POUR  
OUVERTURES LATERALES  
DU VETEMENT**

**PNEUMATIC BACK SHOVELS FOR POSTERIOR  
DRESSED OPENINGS**

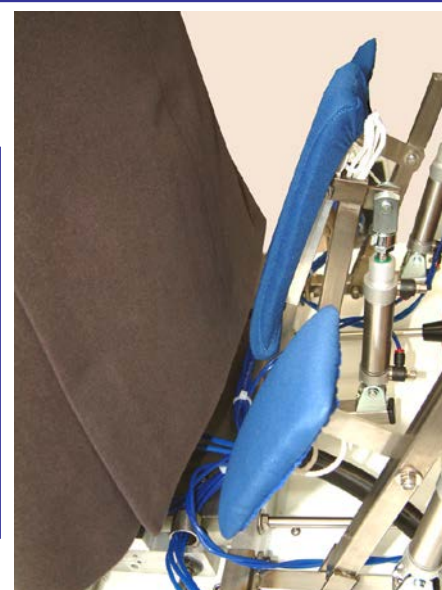



MINIMUM  
CM 60

PNEUMATIC



MAXIMUM  
CM 140

ESCLUSIONI MOVIMENTI "EASY"  
MOUVEMENTS EXCLSION " EASY "  
EXCLUSIONS MOUVENETS " EASY "



REGOLATORE ELETTRONICO SOFFIATURA  
ELECTRONIC BLOWING-POWER REGULATOR  
REGULATEUR PUISSANCE SOUFFLERIE ELECTRON.



9 Program.

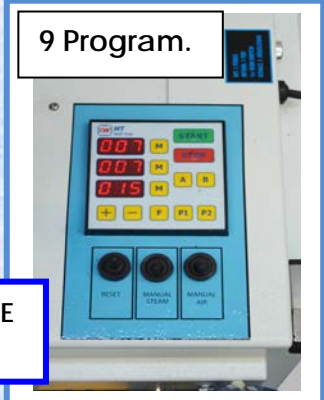

PROGRAMMATORE  
ELETTRONICO

PINZE-CLAMPS-PINCES

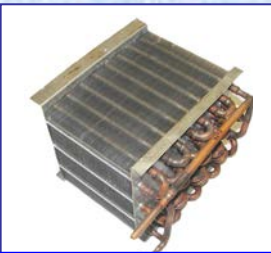

RADIATORE PER ARIA CALDA  
STEAM-RADIATOR FOR HOT AIR  
RADIATEUR VAPEUR POUR AIR CHAUDE



SURRISCALDATORE VAPORE  
INOX STEAM SUPERHEATERS  
SURCHAUFFER VAPEUR INOX

## OPTIONALS\*:



ELECTRO-STEAM IRON (CV-1)  
STEAM-STEAM IRON \*\*\*  
LTS 15 BOILER of Kw 9 or 12  
(ELECTRONIC)  
ENERGY SAVER RC-8

ROT . BASE

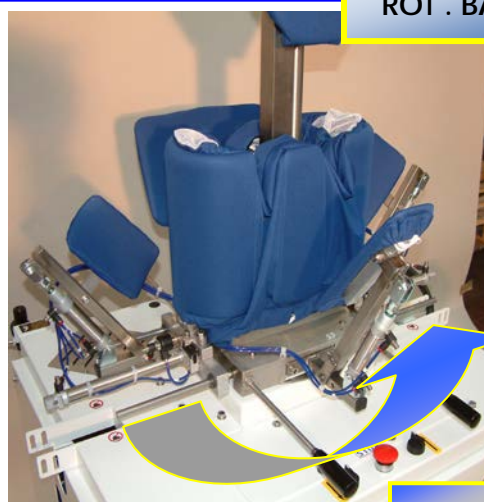

180 °



FER ELECTRO-VAPEUR (CV-1)  
FER VAPEUR-VAPEUR \*\*\*  
CHAUDIERE LT 15 Kw 9 ou 12  
(ELETTRONIQUE)  
RECUPERATEUR ENERGIE RC-8



FERRO ELETTROVAPORE (CV-1)  
FERRO VAPORE – VAPORE \*\*\*  
CALDAIA LT 15 da Kw 9 o 12  
(ELETTRONICA)  
RECUPERATORE ENERGIA RC-8

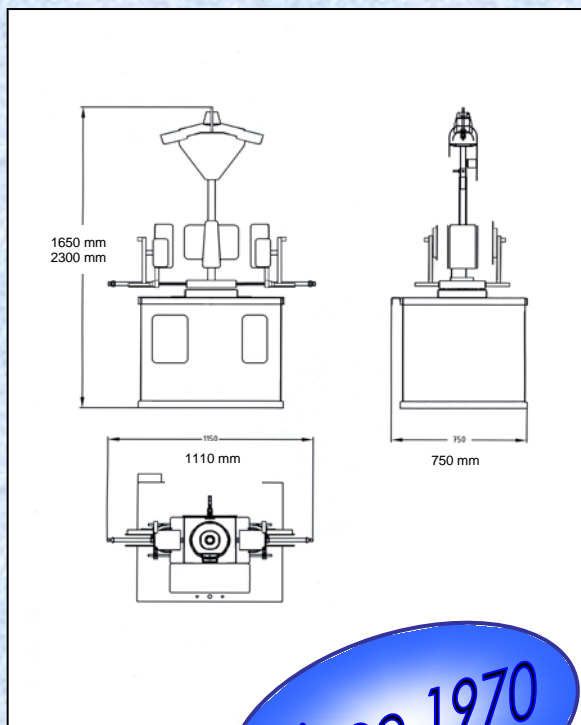

Since 1970

MOTORE SOFFIATURA  
BLOWING MOTOR  
MOTEUR SOUFFLERIE

Hp 1,7

VALVOLA VAPORE  
STEAM VALVE  
VANNE VAPEUR

Pneumat.  
1/2 "

CILINDRI PNEUMATICI  
PNEUMTIC PISTONS  
VERRINS PNEUMAT.

Inox /  
Viton

BUSTO  
DUMMY  
BUSTE

Inox / Alum.  
100 %

RESISTENZE CALDAIA \*  
BOILER ELEMENTS\*  
RESISTANCES CHAUDIERE\*

9 # 12  
KW

CONSUMO VAPORE ( SENZA CALDAIA)  
STEAMCONSUMPTION ( WITHOUT BOILER)  
CONSOMATION VAPEUR ( SANS CHAUDIERE)

18 - 20  
Kg/h  
5 Bar

# COCCHI srl

via Pacinotti 19/a – 40017 San Giovanni in Persiceto – Bologna – Italy  
tel. ++39 051 821787- fax ++39 051 826935  
web site : [www.cocchi.net](http://www.cocchi.net) email : [info@cocchi.net](mailto:info@cocchi.net)

